

JULIET 30 Z



30 m



IP40



BESCHREIBUNG | DESCRIPTION

elegante Scheibenleuchte für sehr anspruchsvolle Architekturen, gefasst in einem dezent umlaufenden Aluminiumrahmen

elegant edge luminaire for very demanding architectures, kept in a discreet circumferential aluminium frame

Erkennungsweite 30 m
viewing distance

Schutzart IP40
protection degree

Schutzklasse I
protection class

Gehäuse Aluminium, Scheibe Acrylglas
housing aluminium, acrylic glass pane

Montageart Wandaufbau (WA)
mounting wall mounting (WA)
Wandeinbau (WE)
wall installation (WE)
Deckenaufbau (DA)
ceiling mounting (DA)

Piktogramm Piktogrammsatz enthalten
pictogram set of pictograms included

Serie S

Serie P

Zentralbatterie | *central battery*

TECHNISCHE DATEN | SPECIFICATIONS

Anschlussspannung <i>supply voltage</i> (AC/DC)	Anschlussleistung <i>power rating</i> (AC/DC)	Umgebungstemperatur <i>ambient temperature</i>	Gewicht <i>weight</i>
230 V / 216 V	WA / WE: 8,0 VA / 5,0 W DA: 11,0 VA / 8,0 W	-10 °C <> +40 °C	WA / WE: 1,4 kg DA: 2,6 kg

MABE | DIMENSION (mm)

Wandaufbau (WA)
wall mounting (WA)

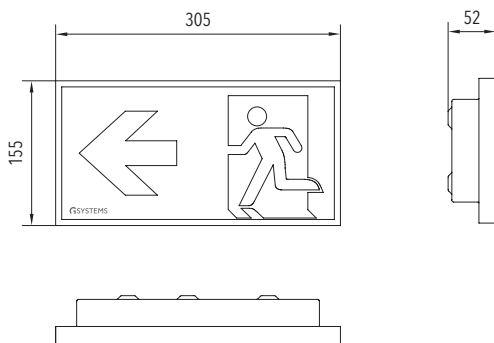

Deckenaufbau (DA)
ceiling mounting (DA)

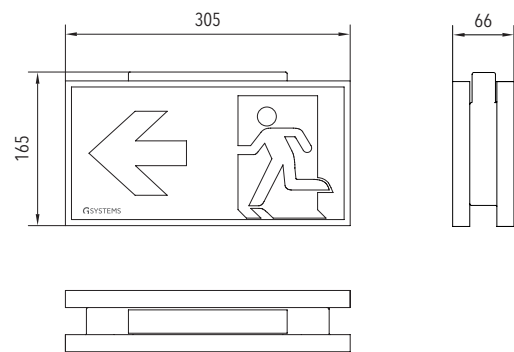

Wandebau (WE)
wall installation (WE)

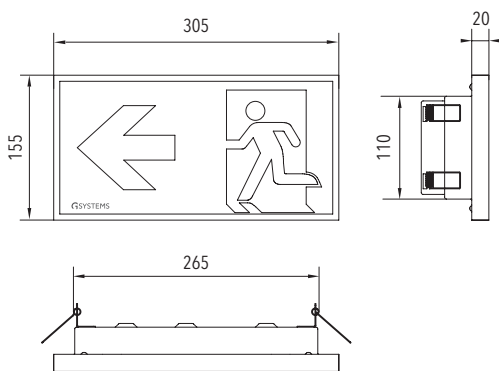

Wandausschnitt
section for installation

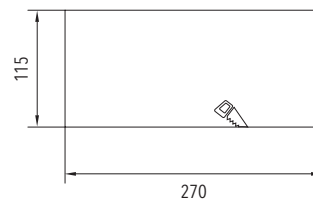

ZUBEHÖR | ACCESSORIES

Bezeichnung designation	Art.-Nr. item no
Wandausleger wall bracket	1219000078
Wandebaufestigung wall installation attachment	1219000079
Sonderpiktogramme special pictogram	

